



SDC-010A2(U)/ SDC-020A2(U)/SDC-040A2(U)/SDC-075A2(U)/SDC-100A2(U)

Thank you for choosing Shihlin SDC Series AC Drive. These instructions will explain the use and precautions of the product. Please read the instructions carefully before installation and use the AC servo drive correctly and safely.

### 1. Safety Instructions

Safety Instructions	
✓	Please contact the professionals to install, operate, maintain and inspect the product.
✓	The safety level could be classified as "Warning" and "Caution".
⚠	Warning: the incorrect operation may cause hazardous situation, and accordingly lead to death or serious injury.
⚠	Caution: the incorrect operation may cause hazardous situation, and accordingly lead to general or minor injury or damage of the object.

Warning	
✓	The front cover plate should not be opened when the AC servo drive is powered on. In addition, the AC servo drive should not be operated when the front cover plate is demounted. Otherwise, the electric shock may be caused due to contacting with the high-voltage terminal and the charging part.
✓	If the wiring needs to be changed or inspection is required, the power supply of the AC servo drive should be turned off first. There is still high voltage inside the AC servo drive before the LED display of the AC servo drive is turned off. Therefore, please don't touch the internal circuit and parts.
✓	The AC servo drive must be earthed correctly.
✓	Please don't operate with wet hands, don't touch the heat sink, and don't plug and unplug the cable; or electric shock may be caused.

Caution	
✓	Voltage applied to each terminal must be the one specified in the user manual; otherwise, failure or damage may be caused.
✓	Do not operate a voltage-resistant test for the parts inside the AC servo drive because semiconductors in AC servo drive may be easily damaged due to high-voltage breakdown.
✓	Do not touch the AC servo drive because the temperature of the AC servo drive is very high when it is powered on or right after disconnecting the power supply, only built-in keypad is touchable, otherwise, scalds may occur.
✓	Failure or damage may be caused due to wrong wiring.
✓	Do not reverse the polarities (+, -) by mistake, otherwise failure or damage may be caused.
✓	Please install the AC servo drive on nonflammable walls without holes (to avoid contacting with the cooling fin of the AC servo drive from the back). If the AC servo drive is installed on or close to flammable objects it may cause a fire.
✓	Please disconnect the inverter from power supply in case of failure. Overload current passes through the inverter continuously may cause a fire.
✓	Do not connect a resistor directly to the DC terminals +P and -N. Doing so could cause a fire.

### 2. Product Model

#### Drive model designation

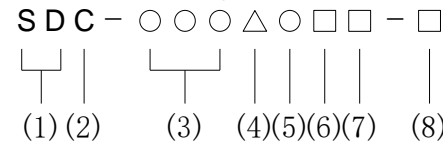

- Drive code : SD stands for the servo drive.
- Model code : C
- Capacity : The output power of the motor. These three digits stand for the output power of the motor after multiplying by 1/10. Example: 020 represents 200 w , 100 represents 1000 w
- Communication type: A: Modbus communication ; C : CANOpen communication(Developing) ; E : EtherCAT communication(Developing)
- Voltage type : The input power supply specifications.  
A2: Single phase, 200 to 240Vac
- Model code : Blank : General type
- Safety certification: Blank : Complying with CE only ; U: Complying with both CE and UL
- Design code : Blank : General ; Sxx: Customized or dedicated.

#### Motor model designation

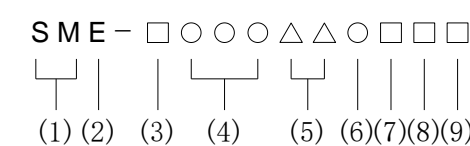

- Motor code: SM stands for the servo motor
- Model code: E
- Inertia classification: In accordance with the motor inertia codes below.

Code	Category			
L	Low			
M	Medium(SDC does not currently support)			
H	High(SDC does not currently support)			

- Capacity : Rated output power:

Code	010	020	040	075	100
motor power (W)	100	200	400	750	1000

- Rated speed: The rated output speed of motor:

Code	20	30
Rated speed (rpm)	2000	3000

- Encoder type: Shihlin servo motor encoder type

Code	S(Optical)	M(Optical)	T(Magnetic)	N(Magnetic)
Single-turn resolution	22	22	17	17
Multi-turn resolution	-	16	-	16

- Brake and oil seal: Used to represent whether the motor is equipped with brake and oil seal according to the codes below:

Code	A	B	C	D
Brake	—	●	—	●
Oil seal	—	—	●	●

- Keyway and wire type: Motor keyway and line type selection according to the following codes:

Code	A	B	C	D
Keyway	—	●	—	●
Back side cable	—	—	●	●

- Safety certification : Motor passed safety certification according to the following code:

Code	CE certification	conform UL/CE certification
Code	—	U

### 3. Installation Environment

Ambient temperature	0 ~ +55°C (non-freezing), ✖If environment temperature is above 45°C, forced cooling will be required
Ambient humidity	Below 90%Rh (non-condensing).
Storage temperature	-20 ~ +65°C.
Surrounding	Indoor, no corrosive gas, no flammable gas, no flammable dust.
Altitude	Altitude below 1000 meters
Vibration	5.9m/ s <sup>2</sup> (0.6G)below
Protection level	IP20
Pollution degree	2

### 4. Installation and Wiring

- Please install the inverter vertically in order not to reduce the heat dissipation effect:

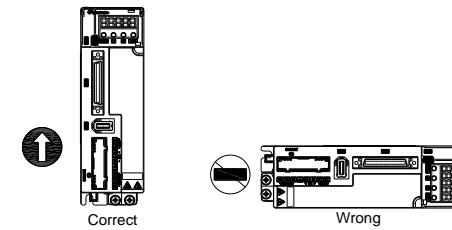

- Please follow the installation restrictions shown below to ensure enough ventilation space for inverter cooling and wiring space:

#### Arrangement of single AC servo drive:

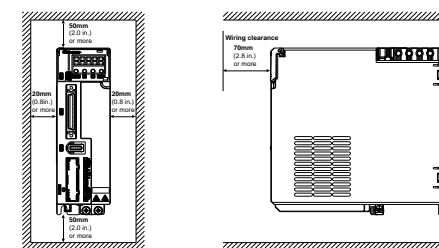

#### Arrangement of multiple AC servo drives:

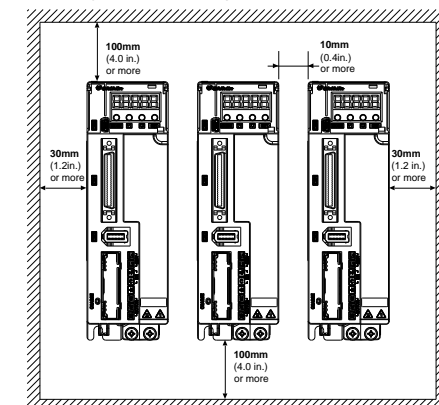

### 5. Terminal Connection Diagrams

Shihlin servo drive power supply wiring would be the single-phase power supply. According to the diagram below, Power ON would be contact a, Power OFF and Alarm Processing would be contact b. 1MC/a would be self-holding power supply and 1MC would be electromagnetic contactor.

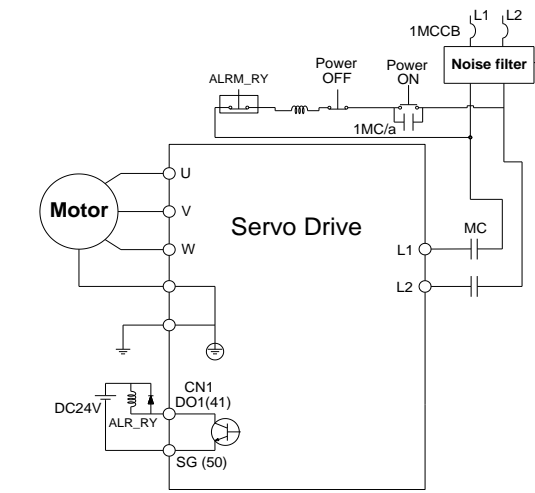

### 6. Description of drive terminals and sockets

Name	Terminal name	Description	
Power supply input	L1, L2	Connect to single-phase AC power source	
Motor power input terminal	U, V, W, PE	Connect to servo motor power input.	Terminal code
			Wire color
		U	Red
		V	White
Regenerative resistor terminal	P, C	External resistor	Remove the original wiring and connect to a regenerative resistor externally
		Internal resistor	P and C terminals are connected to the internal regenerative resistor
Ground terminal		Connect to the power ground and motor ground. That is, the location of the green screw outside the controller.	
P: + terminal N: - terminal	P, N	If a braking module is used, please connect the "+" terminal of braking module to the "P" terminal of the servo drive and the "-" terminal to the "N" terminal. A braking module is optional to be purchased as it usually doesn't have to be connected. Only if the negative work produced by the servo motor is too strong, the braking module is needed to counteract the regenerative energy.	
I/O connector	CN1	Connect to the upper controller	
Encoder socket	CN2	Connect to the encoder	
RS-485 port	CN3/CN3L	Connect to RS485 or CAN device.	
USB port	CN4	Connect to USB port of PC.	
Absolute encoder battery end connection	CN5	Connect to absolute encoder battery set (optional purchase)	

- Note 1 : Keep L1, L2 and U, V, W away from other wires. The distance should be at least 30cm.
- Note 2 : When the power supply is OFF, do not touch the power cable L1, L2, U, V, W and P, C, N because the large capacitor inside the drive contains a large amount of electric charges. The drive will be touchable only when the charging indicator is out.
- Note 3 : If a longer encoder cable is needed, please use a twisted-pair cable which isolates from the ground. The cable should not exceed 20cm. If a cable which exceeds 20cm is needed, please double the diameter of the cable to ensure the signal strength.

### 7. Motor U, V, W lead wire connector specifications

- U, V, W wiring connector specifications of Shihlin's low inertia motor (Female connector):

Drive capacity	Motor model	With brake	Without brake
100W	SME - L01030□□□□		
200W	SME - L02030□□□□		
400W	SME - L04030□□□□		
750W	SME - L07530□□□□		
1KW ( 80 frame )	SME - L10030□□□□		

The following table shows the UVW lead wire connector's signal of the low inertia motor :

PIN	Signal	Wire color
1	U	Red
2	V	White
3	W	Black
4	PE	Green/yellow (green at the bottom)
5	NC	Black ( electromagnetic brake)
6	NC	Black (electromagnetic brake)

Note: The wiring above is the wiring of motor connector.

► U, V, W connector specifications of Shihlin low/ medium inertia motor (Male connector) (SDC does not currently support)

Drive capacity	Motor model	
1KW ( 130 frame )	SME - L10020□□□□	
	SME - M10020□□□□	

► The table below shows the UVW lead wire connector's signal of 130-frame 1kW motor:

PIN	Signal
A	NC
B	U
C	V
D	W
E	PE
F	NC(electromagnetic brake)
G	NC(electromagnetic brake)
H	NC

Note: The wiring above is the wiring of motor connector.

► Cable selection

Drive Model	Power cable [mm2(AWG)]		
	L1, L2	U, V, W	P, C, N
SDC - 010A2□	2(AWG14)	1.5(AWG16)	2(AWG14)
SDC - 020A2□			
SDC - 040A2□			
SDC - 075A2□			
SDC - 100A2□			

### 8. CN1 I/O Wiring

CN1 connector (female) - drive side

CN1 connector (male)

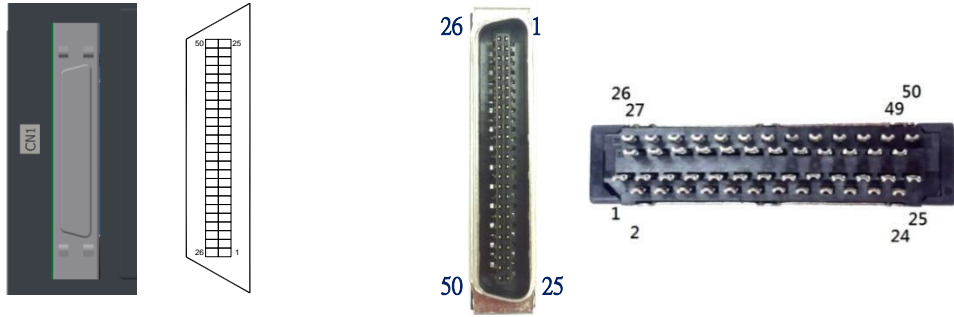

CN1 connector pin order

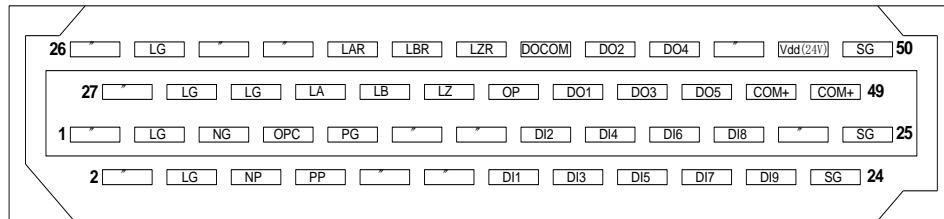

Pin	Code	Function	Pin	Code	Function
1	-	-	2	-	-
3	LG	Ground of analog input signal	4	LG	Ground of analog input signal
5	NG	Input pulse	6	NP	Input pulse
7	OPC	Open collector power input	8	PP	Input pulse
9	PG	Input pulse	10	-	-
11	-	-	12	-	-
13	-	-	14	DI1	Digital input 1
15	DI2	Digital input 2	16	DI3	Digital input 3
17	DI4	Digital input 4	18	DI5	Digital input 5
19	DI6	Digital input 6	20	DI7	Digital input 7
21	DI8	Digital input 8	22	DI9	Digital input 9
23	-	-	24	SG	Digital power ground
25	SG	Digital power ground			

Pin	Code	Function	Pi	Cod	Function
26	-	-	27	-	-
28	LG	Ground of analog input signal	29	LG	Ground of analog input signal
30	-	-	31	LG	Ground of analog input signal
32	-	-	33	LA	Phase A pulse output of encoder
34	LAR	Phase A pulse reverse output of encoder	35	LB	Phase B pulse output of encoder
36	LBR	Phase B pulse reverse output of encoder	37	LZ	Phase Z pulse output of encoder
38	LZR	Phase Z pulse reverse output of encoder	39	OP	Phase Z pulse output of encoder (Open-collector)
40	DOC	Common port of digital output	41	DO1	Digital output1
42	DO2	Digital output 2	43	DO3	Digital output 3
44	DO4	Digital output 4	45	DO5	Digital output 5
46	-	-	47	COM	Digital input power
48	Vdd(2)	+24V power output	49	COM	Digital input power
50	SG	Digital power ground			

Digital input in SINK type:

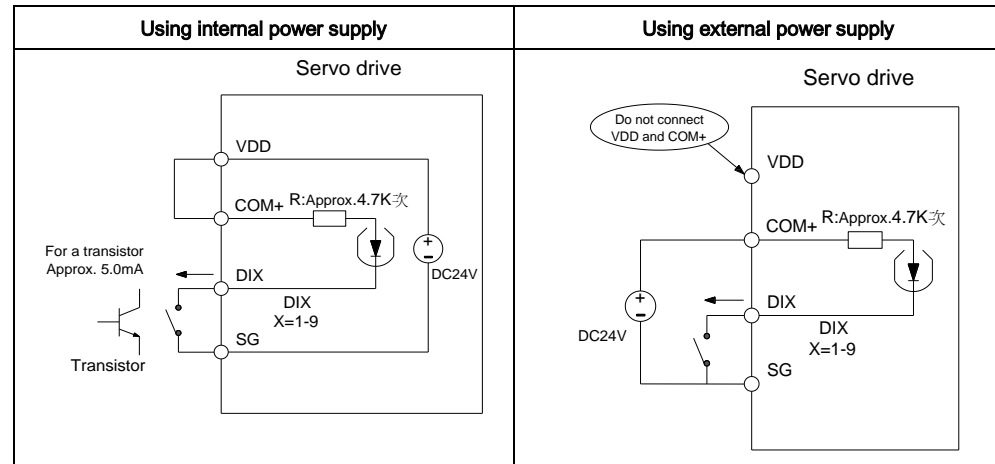

Digital input in Source mode

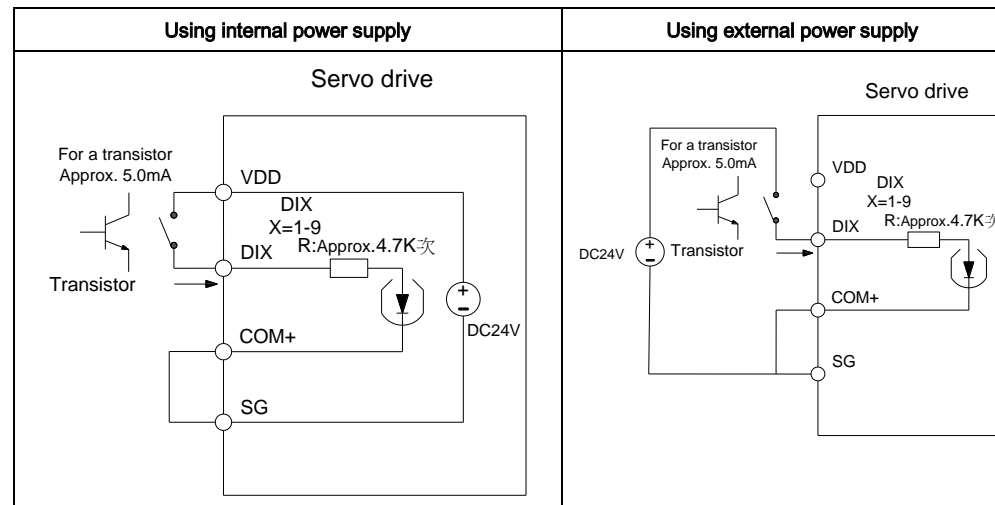

Digital output

It can drive Lamp, Relay and photocoupler. Add a diode when the Relay is loaded, and add a resistor for suppressing surge current when the external Lamp is loaded. (Permissible current: below 40 mA; surge current: below 100 mA)

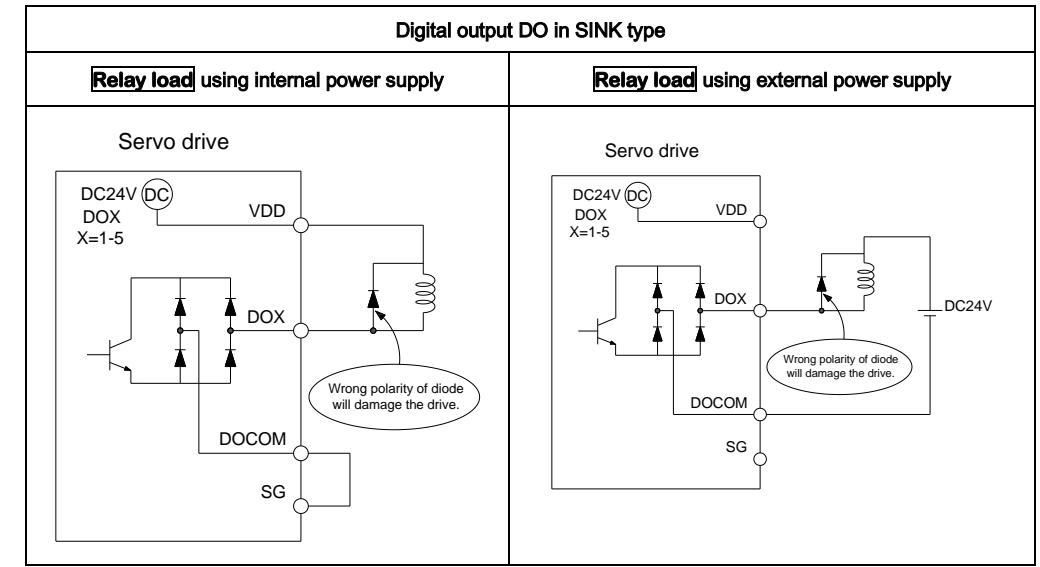
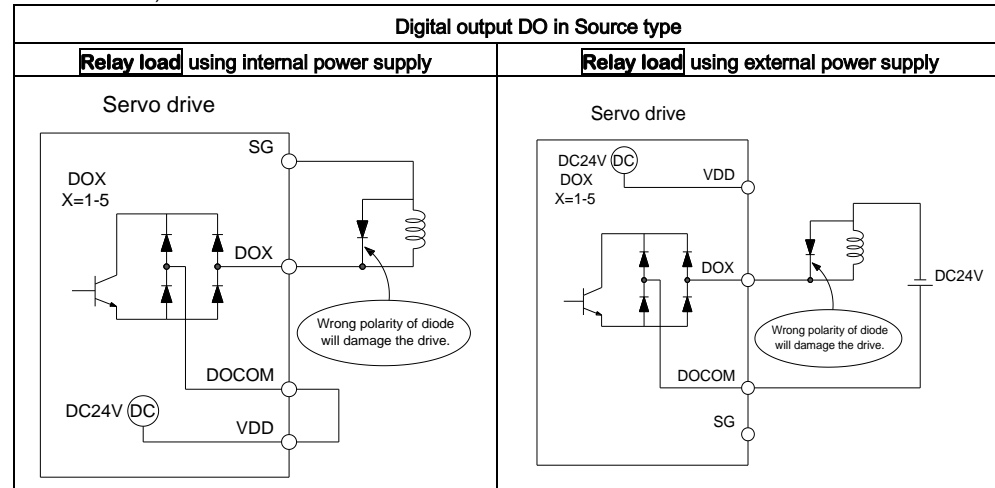

### 9. Specifications of encoder's lead wire connector

CN2 connector (female)

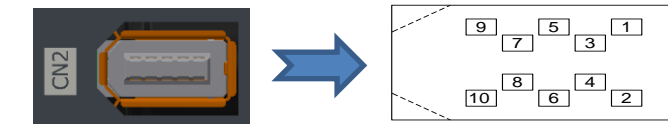

Drive capacity	Motor model	
100W	SME - L01030□□□□	
200W	SME - L02030□□□□	
400W	SME - L04030□□□□	
750W	SME - L07530□□□□	
1KW	SME - L10030□□□□	
1KW	SME - L10020□□□□	
1KW	SME - M10020□□□□	

Drive Side			Motor Side Pin No.	
Pin No.	Pin mark	Signal Description	Quick connector (low capacity)	Military Connector (medium capacity)
1, 3	Vcc(5V)	5V power supply for encoder	7	B
2, 4	GND	Ground of battery	8	F
	GND	Ground of encoder	4	A
5	Vcc(3.6V)	3.6V for battery	3	H
6	ENCP	Encoder communication (+)	6	D
7	ENCN	Encoder communication (-)	5	E
-	Shielding	Shielding	9	I

Driver model	Encoder wiring(AWG)			
	Standard	Standard Length	Number of Cable Cores	AWG
SDC-010A2□	UL1332	2M	10	AWG26
SDC-020A2□	UL1332	2M	10	AWG26
SDC-040A2□	UL1332	2M	10	AWG26
SDC-075A2□	UL1332	2M	10	AWG26
SDC-100A2□	UL1332	2M	10	AWG26

### 10. CN3/CN3L communication port wiring

Note:Shihlin servo RJ45 pin definition is different from the standard RJ45 definition, please pay attention when wiring.

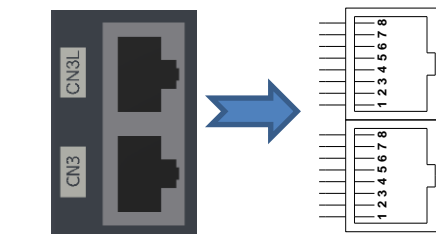

Pin No.	Pin marking	Function
1	CAN_+	Differential signal CAN_P
2	CAN_-	Differential signal CAN_N
3	GND	CAN Signal ground
4	RS-485-B	Transfer/receive data with the differential terminal B
5	RS-485-A	Transfer/receive data with the differential terminal A
6-8		NC

### 11. CN4 USB communication port

CN4 port is for USB communication. With the Shihlin servo communication software, users could connect it to the computer, then set parameters, monitor the status, test the operation, etc.

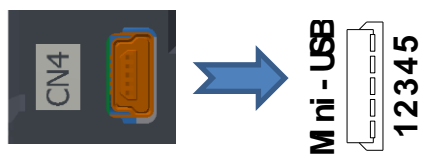

Pin No.	Pin marking
1	GND
2	NC
3	D+
4	D-
5	+5V

### 12. CN5 battery power socket

When using a servo motor with an absolute encoder, it should be connected to the battery set of the absolute encoder. Parameter could be set after connecting the battery to CN5.

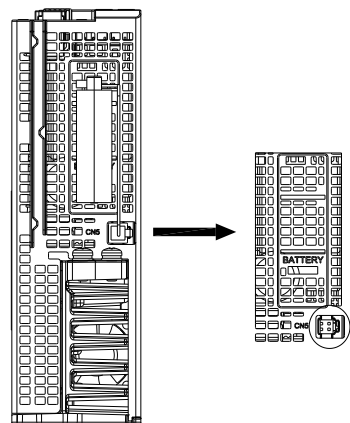

Pin NO	Pin function	Function
1	Vcc(3.6V)	3.6V for battery
2	GND	Ground of battery

### 13. Standard wiring instruction

- Procedure control mode(Pr Mode) wiring diagram

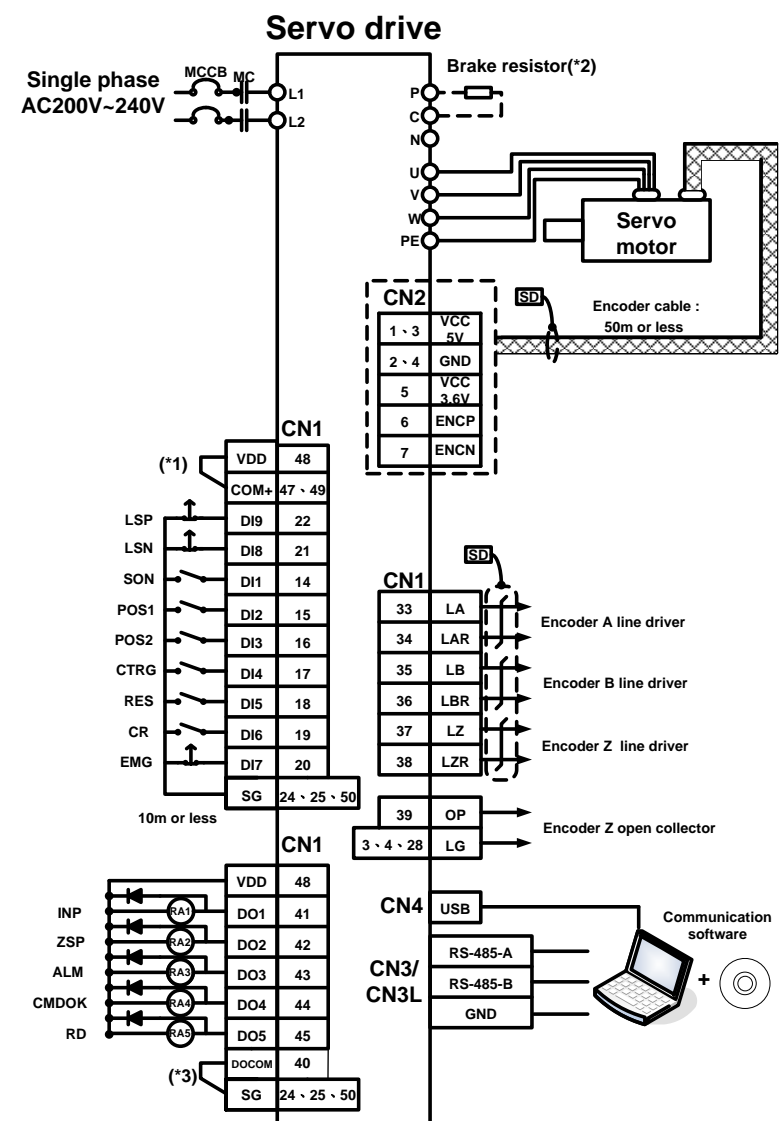

Note: 1. If an external power is applied, do not connect VDD and COM+.

- Please refer to the user manual section 3.1 for the wiring of regenerative resistor and braking unit.
- Please refer to the user manual section 3.2.4 for DO SINK or Source type wiring.

After the wiring for procedure control mode is completed, the following parameters should be set to operate basic position control.

Parameter	Name	Setting value	Content
PA01(note 1)	Control mode option	□□□0	Position control mode
PA02(note 2)	Auto tuning	0002	Auto tuning mode 1
PA03	Auto-tuning response level setting	0012	Middle response
PA06	Electronic gear numerator	1	Set the numerator as "1"
PA07	Electronic gear denominator	1	Set the denominator as "1"
PA13	Pulse command option	Refer to section 8. 3 parameter description	
PD15(note 1)	Digital input filter time option	2	Filter time constant is "4ms"

Note 1: The drive must be shut off and restarted after changing the parameter, or the operation will not be implemented.

Note 2: The parameter cannot be set when SON-SG is connected.

- Position control mode(Pt Mode) wiring diagram

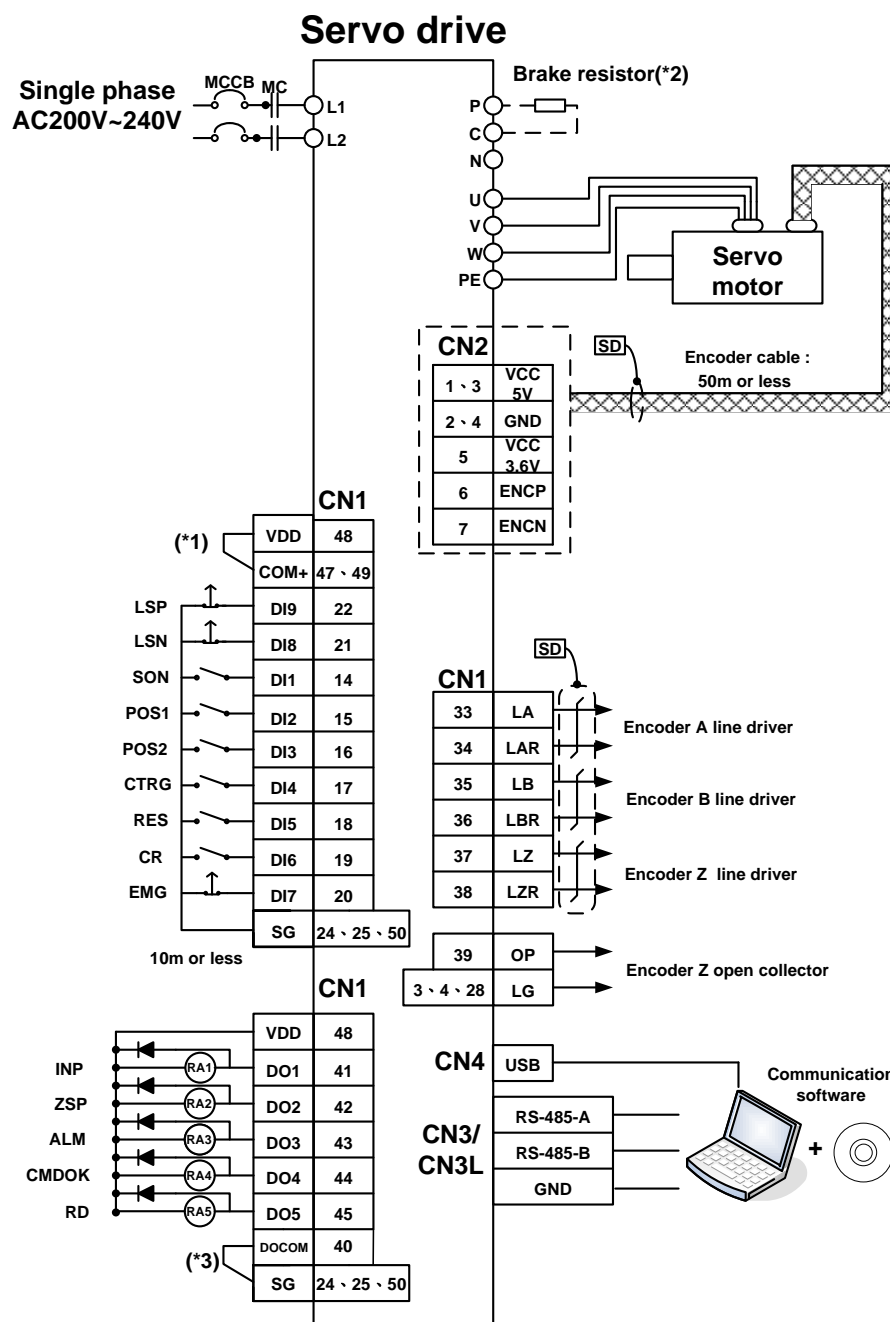

Note: 1. If an external power is applied, do not connect VDD and COM+.

- Please refer to the user manual section 3.1 for the wiring of regenerative resistor and braking unit.
- Please refer to the user manual section 3.2.4 for DO SINK or Source type wiring.

After the wiring for position control mode is completed, the following parameters should be set to operate basic position control.

Parameter	Name	Setting value	content
PA01(note 1)	Control mode option	□□□0	Position control mode
PA02(note 2)	Auto tuning	0002	Auto tuning mode 1
PA03	Auto-tuning response level setting	0012	Middle response
PA06	Electronic gear numerator	1	Set the numerator as "1"
PA07	Electronic gear denominator	1	Set the denominator as "1"
PA13	Pulse command option	Refer to section 8. 3 parameter description	
PD15(note 1)	Digital input filter time option	2	Filter time constant is "4ms"

Note 1: The drive must be shut off and restarted after changing the parameter, or the operation will not be implemented.

Note 2: The parameter cannot be set when SON-SG is connected.

- Speed control mode (S Mode)wiring diagram

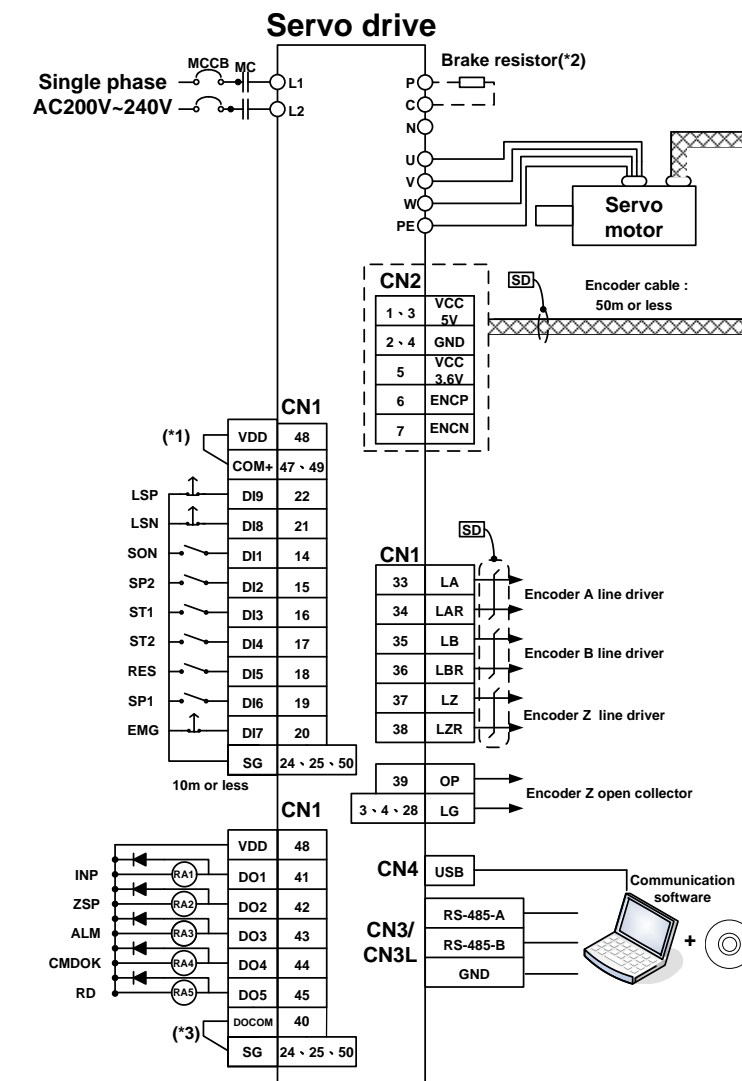

Note: 1. If an external power is applied, do not connect VDD and COM+.

- Please refer to the user manual section 3.1 for the wiring of regenerative resistor and braking unit.
- Please refer to the user manual section 3.2.4 for DO SINK or Source type wiring.

After the wiring for speed control mode is completed, the following parameters should be set to operate basic speed control.

Parameter	Name	Setting value	Content
PA01(note 1)	Control mode option	□□□2	Speed control mode
PC05	Internal speed command 1	1000	Speed command 1 is 1000 rpm
PC06	Internal speed command 2	1500	Speed command 2 is 1500 rpm
PC07	Internal speed command 3	2000	Speed command 3 is 2000 rpm
PC01	Acceleration time constant	1000	Acceleration time constant is 1000ms
PC02	Deceleration time constant	500	Deceleration time constant is 500ms
PC03	S-curve acceleration/deceleration time constant	0	Disabled
PD15(Note 1)	Digital input filter time option	2	Filter time constant is "4ms"

Note 1: The drive must be shut off and restarted after changing the parameter, or the operation will not be implemented.

● Torque control mode wiring diagram (T Mode)

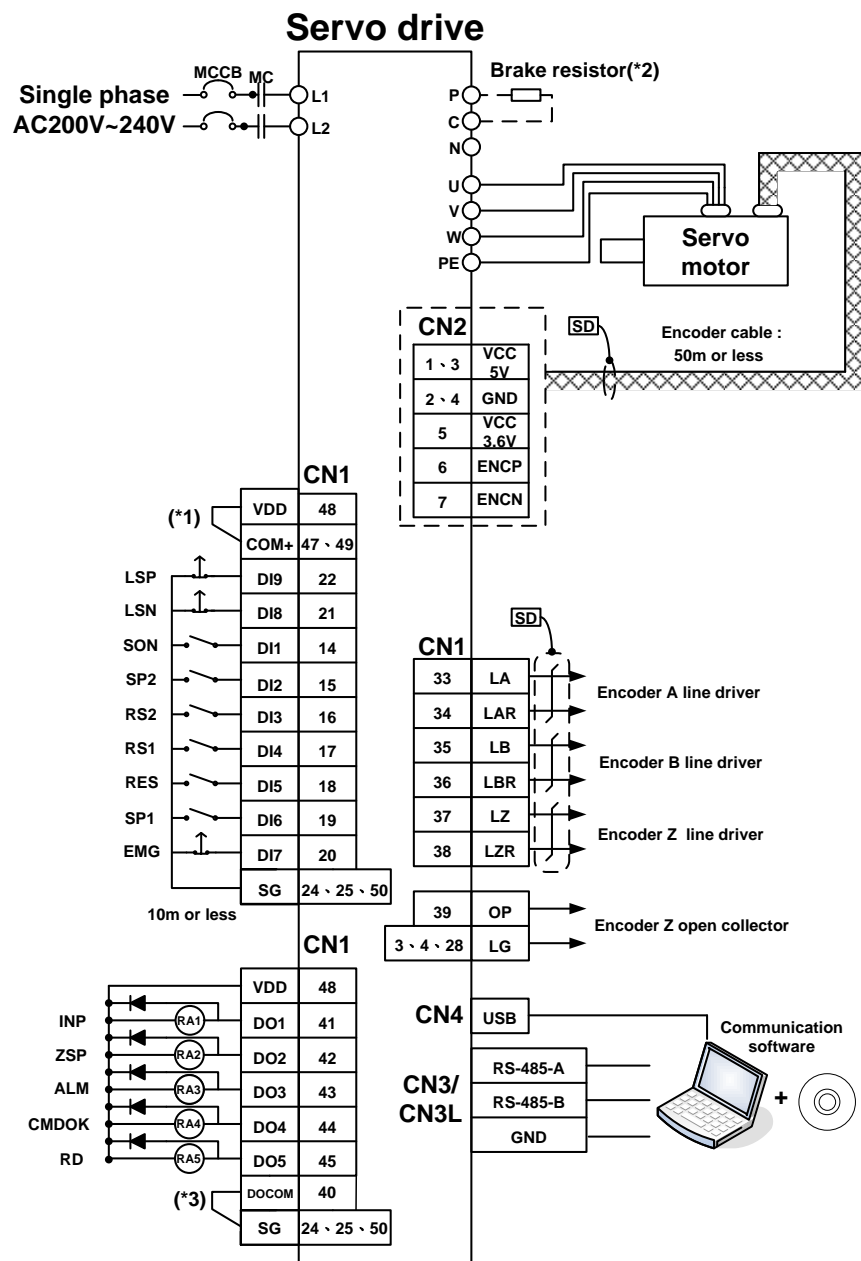

- Note: 1. If the external power is applied, do not connect VDD and COM+.  
 2. See section 3.1 for the wirings of brake resistor.  
 3. See section 3.2.4 for DO sink or source wiring.

After the wiring for torque control mode is completed, the following parameters should be set to operate basic torque control and speed limitation.

Parameter	Name	Setting value	content
PA01(Note 1)	Control mode option	□□□4	Torque control mode
PC05	Internal speed limit 1	1000	Internal speed limit 1 is 1000 rpm
PC06	Internal speed limit 2	1500	Internal speed limit 2 is 1500 rpm
PC07	Internal speed limit 3	2000	Internal speed limit 3 is 2000 rpm
PC01	Acceleration time constant	1000	Acceleration time constant is 1000ms
PC02	Deceleration time constant	500	Deceleration time constant is 500ms
PC03	S-curve acc./dec. time constant	0	Disabled
PD15	Digital input filter time option	2	Filter time constant is "4ms"
PA05(Note 1)	Internal torque limit 1	50	50% of maximum torque as a limit

Note 1: The drive must be shut off and restarted after changing the parameter, or the operation will not be implemented.

14. Dimensions of the servo drive

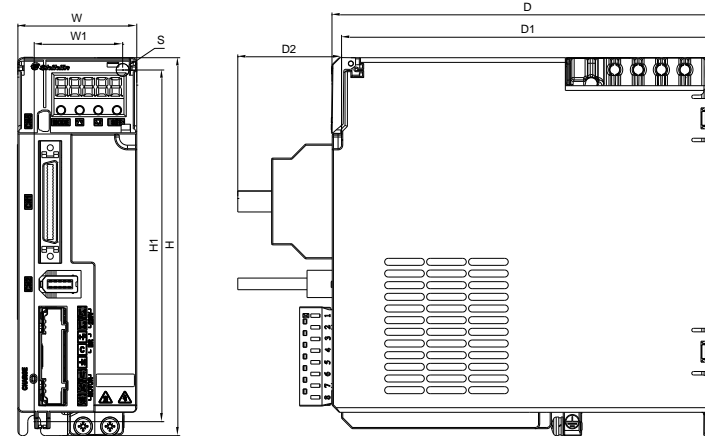

Type	Frame	W	W1	H	H1	D	D1	D2	S
SDC-010/020/040/075/100A2□	A	51	38	162	150	164	160	80	5.5

Unit:mm

15. Motor dimensions

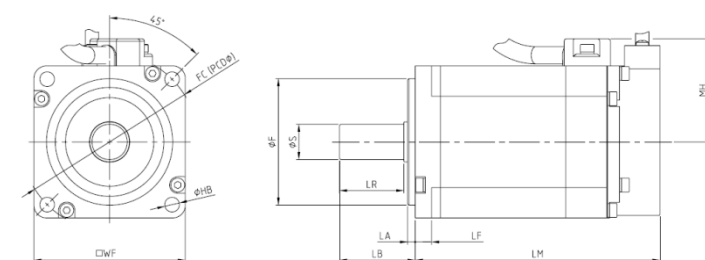

Note: ( ) stands for the length of servo with electromagnetic brake

Type	WF	S	F	LA	LB	LF	LR	MH	LM	FC	HB
SME-L005(B)	40	8	30	2.5	25.5	5.5	20	31	64.5(99.2)	46	2-φ4.5
SME-L010(B)	40	8	30	2.5	25.0	5.5	20	32	97.8(132.5)	46	2-φ4.5
SME-L020(B)	60	14	50	3	30	6.5	25.5	42	94.2(129.2)	70	4-φ5.8
SME-L040(B)	60	14	50	3	30	6.5	25.5	42	114.2(149.2)	70	4-φ5.8
SME-L075(B)	80	19	70	3	40.0	7.5	35.3	52	119.2(158.2)	90	4-φ6.6
SME-L100(B)	80	19	70	3	40.0	7.5	35.3	52	159.2(203.5)	90	4-φ6.6

Unit:mm



Type	QL	QK	W	U	Y
L020(B) \ L040(B)	3	20	5 <sup>h</sup> <sub>0.03</sub>	3	Screw: M4 Depth: 15
L075(B)\L100(B) ( 80 frame)	5	25	6 <sup>h</sup> <sub>0.03</sub>	3.5	Screw: M5 Depth: 20

16. SDC complies with global standards

- Standard compliance
- (1) Compliance with EU directives  
SDC servo drives comply with EMC directive (2014/30/EU) and Low-voltage directive (2014/35/EU)
- (2) Safety regulations and EMC standards  
SDC servo drives comply with safety standards IEC/EN61800-5-1 and EMC standards EN61800-3.
- (3) Compliance with USA/Canada regulations  
This servo drive design complies with UL 508C and CSA C22. 2 No. 274-17.

- (a) Installation  
The minimum size of the distribution box is 200% of the size of the SDC servo drive. For ventilation of the fan and to keep the ambient temperature below 55°C, only copper wires can be used for wiring. The servo drive should be installed in a metal distribution box.
- (b) Overload protection feature  
The SDC servo drive has overload protection function. (It is specified based on 120% of the rated current of the servo driver (full load current).)
- (c) Motor overheat protection  
There is no temperature sensor inside the motor, and the SDC series don't have overheat protection.
- (d) Capacitor discharge  
After the power is turned off, do not touch the servo and its terminals immediately. The capacitor discharge takes 20 minutes.

(e) About wiring protection

When installing equipment in the United States, branch circuit protection is based on the National Electrical Code and local regulations. When installing equipment in Canada, branch circuit protection is based on the Canadian Electrical Code and provincial regulations.

(4) Used in Canada only

A surge absorber should be installed on the power input end of the equipment and shall be rated at 240V (phase to ground) and 240V (phase to phase). It must be suitable for overvoltage category III and provide protection for withstanding a rated impulse voltage peak of 4kV(or equivalent).

- Correct use

Use these devices according to the standard (such as voltage, temperature, etc. Please refer to SDC Manual for more details.)

(1) Power wiring: According to UL/CSA standards, only 75°C CU wires are allowed.

Drive	Wire [AWG (mm2)]			
	L1, L2	U, V, W	P, C, N	⊕
SDC - 010A2□	AWG14 (2)	AWG16 ( 1.5 )	AWG14 (2)	AWG16 ( 1.5 )
SDC - 020A2□				
SDC - 040A2□				
SDC - 075A2□				
SDC - 100A2□				

(2) Torque for fixing terminal block: The crimp terminals must comply with UL standards. The terminals must be sheathed with insulating tube to prevent direct contact:

Drive	Recommended Torque [in-lbs(N-m)]		
	U, V, W	L1, L2, P, C, N	⊕
SDC - 010A2□	7.1~10.5 (0.8~1.2)	7.1~10.5 (0.8~1.2)	12 (1.4)
SDC - 020A2□			
SDC - 040A2□			
SDC - 075A2□			
SDC - 100A2□			

(3) Example for no-fuse breaker selection:

Drive	UL certified current-limiting circuit breaker	Example
SDC-010A2□	240 V, 5 A	NF50-SVFU 5A
SDC-020A2□		
SDC-040A2□	240 V, 10 A	NF50-SVFU 3P 10A
SDC-075A2□	240 V, 15 A	NF50-SVFU 3P 15A
SDC-100A2□		

(4) Wiring example of peripherals:

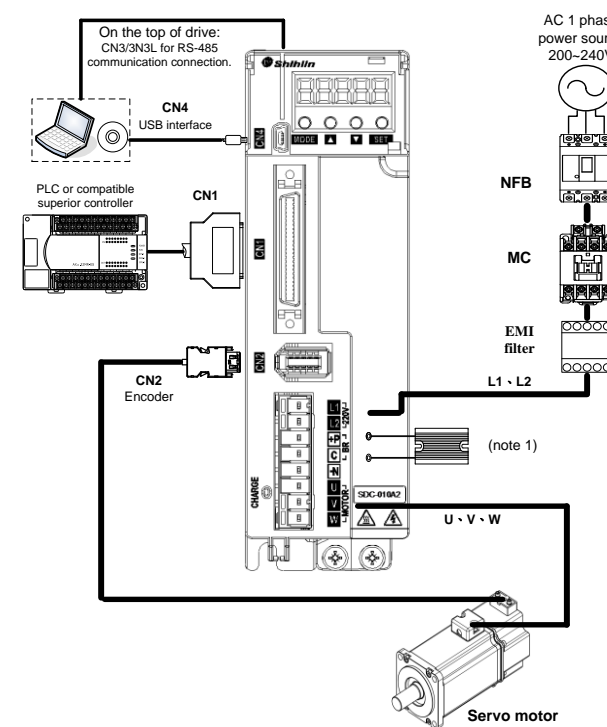

17. Others

► For excelsior products, the parameters and contents may be modified, please contact the agent or refer to Shihlin websites (<http://automation.seec.com.tw/>) to download the latest version.